

#4 Cheese Country Bridge 18 Rehab

State of Wisconsin  
 Department of Natural Resources  
[dnr.wi.gov](http://dnr.wi.gov)

**Motorized Recreation Grant Application**

For: (choose all that apply)

Form 8700-159 (R 04/22)

Page 1 of 5

**Due Date: April 15**

- ATV/UTV Trail Aid
- Snowmobile Trail Aid

**Notice:** Completion of this form is required under Wisconsin Statutes 23.09(26) and 23.33. Failure to complete this form will result in denial of financial assistance. Personally identifiable information found on this form is not intended to be used for any other purpose. The Department of Natural Resources (DNR) may provide this information to requesters as required by Wisconsin's Public Records law {ss. 19.31 – 19.39, Wis. Stats.}.

**Instructions:** Applications may combine more than one source of funds. They may be submitted for consideration of traditional ATV, UTV, Snowmobile and Motorized Stewardship funding. Submit one copy of all forms and attachments. See Page 2 for necessary attachments. Send applications to your [Community Services Specialist](#).

DNR Use Only	
Category	Number

**Section 1: Applicant Information**

Applicant / Organization Name Tri County Trails Commission				Check Recipient: Individual other than authorized individual to act on behalf of the applicant. <input checked="" type="checkbox"/> Select if the same as applicant.			
Individual Authorized to Act on Behalf of Applicant per Resolution Thomas R. Jean				Check Recipient Name (Name to Appear on Check)			
Title Trail Coordinator				Title			
Address 15456 County Shop Road				Address			
City Darlington	State WI	ZIP Code 53530	City	State	ZIP Code		
Telephone Number 608-574-4055		Email Address tandjjean@gmail.com					

**Section 2: Project Information Required for all Projects**

Project Title Cheese Country Trail Bridge # 18 rehabilitation				Current Funded Miles 57.5	New Miles (if applicable) NA
County Lafayette	Township N	Range O E O W	Section ¼ ¼	¼	GPS Coordinates: Lat. _____ Long. _____

**Project Description Summary**

Rehabilitation of Bridge #18 on the Cheese Country Trail over the Pecatonica River in Calamine WI. To include removal of existing deteriorated deck and sub standard railing (also deteriorated). Construction of a new Wheeler wood deck system including new railing, wear surface, approach work and landscaping.

I certify that all maintenance land use agreements are on file.

**Estimated Cost**

Maintenance	Acquisition	Insurance	Development	Bridge Rehab.	Trail Rehab.	Total Estimated Cost
				83,651.92		
Leave Blank – DNR Use Only						

**Applicant Certification**

Printed Name of Authorized Official Thomas R. Jean	Official's Title Trail Coordinator
---	---------------------------------------

As the applicant's authorized official, I certify that, to the best of my knowledge, the information in this application is true and correct.

Signature of Authorized Official

*Thomas R. Jean*

Date Prepared

4-14-2023

# Motorized Recreation Grant Application

Form 8700-159 (R 04/22)

Page 3 of 5

## Appendix A – Required for Bridge Rehab/Replace, New, or Reroute with New Bridge

Bridge Rehab/Replace    
  New Bridge    
  Reroute with new bridge

County Lafayette	Township N	Range <input type="radio"/> E <input type="radio"/> W	Section	1/4 1/4	1/4	GPS Coordinates: Lat. N42deg. 38.745' Long. W090deg. 03.347'
Water Body Name Pecatonica River			Bridge Name Redrock Bridge		County Inventory Number #18	
Funded Trail Name or Number (SNARS if applicable) Cheese Country Trail			Has this bridge site ever received development or rehabilitation funds in the past? <input type="radio"/> Yes <input checked="" type="radio"/> No    Year: _____ \$ _____			
Bridge is located on: <input checked="" type="radio"/> Private property <input type="radio"/> Public property			Old Bridge/Culvert Size _____ New Bridge/Culvert Size _____			
Landowner Where Bridge is Located Pecatonica Rail Transit Commission			Telephone Number		Length of Trail Use Agreement (5 year minimum)	
Current maximum load    >10,000    lbs.		Age of Bridge		Bridge Material		
Proposed maximum load    40,000    lbs.		NA		Concrete inbutements, steel girders & wooden deck		
Sponsoring Club Name Tri County Trail Commission			Club Contact Tom Jean		Telephone Number 608-574-4055	
Do you have your trail bridges posted as to maximum load? <input type="radio"/> Yes <input checked="" type="radio"/> No			What is the maximum load of the other bridges on the system if groomed with this bridge?			
What is the weight of your puller & drag/grading equipment? 10,000 #			40,000#			

What other recreational trail uses are planned for this bridge?  
 ATV's, UTV's, Snowmobile, bikes, horses and pedestrians all use this trail.

If there are other Recreational uses planned, how much of the bridge cost will be paid for by non-snowmobile or non-ATV users?  
 NA

- Yes     No    Have you contacted your local [DNR Water Management Specialist \(WMS\)](#) regarding a permit?
- Yes     No    Is a permit needed? (Please provide any written correspondence from WMS.)
- Yes     No    Have you contacted your County Zoning Dept. regarding a floodplain determination?
- Yes     No    Will an H & H (hydrologic and hydraulic) study be required?

**Bridge Project Detailed Description**

The deck on the existing bridge is severely deteriorated and the railing is sub standard, old and unsafe and the railing is too narrow to get a groomer through. The bridge consists of a old RR bridge designed for train traffic. Therefore the super structure is sound and in good shape. However the deck and rail systems need to be replaced. Jewell Associate Engineers from Spring Green was hired to do a structural analysis and to provide a cost estimate to repair the deck and railing. Their recommendation and cost estimate is the basis of this application.

## Cheese Country Trail Bridge Deck Replacement

Bridge Length

64 ft

### Base Unit Costs - Replace Existing Decking With Panel-lam system

Item	Unit	Estimated South Quantity	Estimated Cost/Unit	South Bridge Cost
Existing Railing Removal	LF	128	\$4.00	\$512.00
Existing Curb Removal	LF	128	\$4.00	\$512.00
Existing Wearing Surface Removal	SF	608	\$2.00	\$1,216.00
Existing Tie Removal	LF	64	\$10.00	\$640.00
Total Material Cost	LF	64	\$685.00	\$43,840.00
Deck Panel Installation	LF	64	\$70.00	\$4,480.00
Proposed Railing Installation	LF	128	\$20.00	\$2,560.00
Wear Course Installation	SF	768	\$3.00	\$2,304.00
Equipment Cost for Deck Installation	HR	40	\$75.00	\$3,000.00
Approach Work Excavation/Fill	CY	75	\$20.00	\$1,500.00
Approach Work Aggregate	CY	22	\$12.00	\$264.00
Seeding/Erosion/Finishing	SY	60	\$5.00	\$300.00
Mobilization	LS	1	\$5,000.00	\$5,000.00
Contingencies	LS	1	15%	\$9,919.20

Totals      \$76,047.20

Engineering      10%      \$7,604.72

Total Project Cost      \$83,651.92

### Cheese Country Trial Bridge

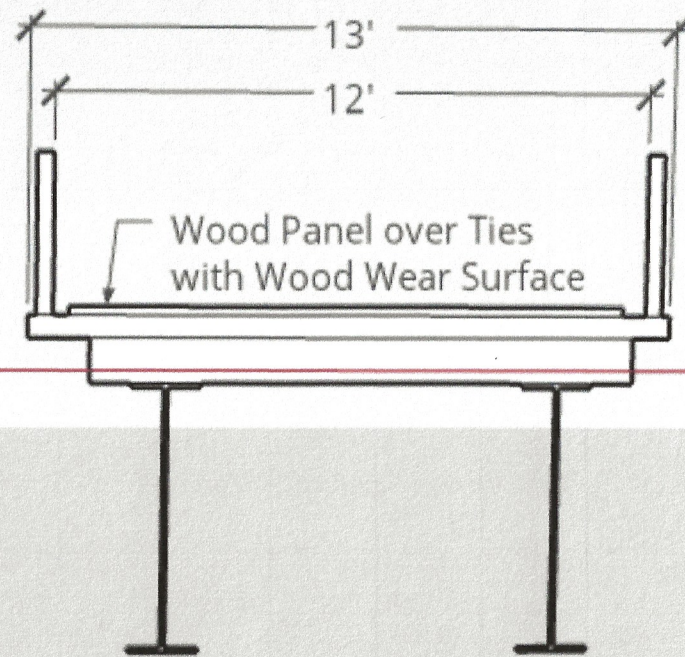
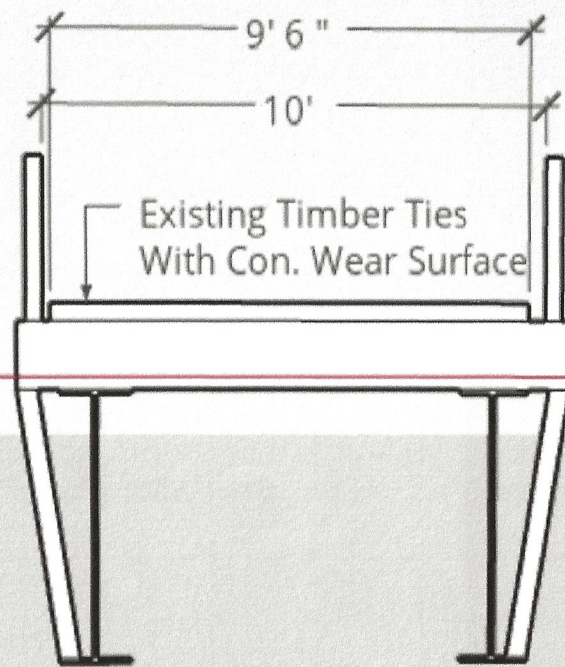

Arthur

To Mineral Point

Blanchardville

Belmont

Calamine

Fayette

Truman

#48  
N 42° 44.442'  
W 090° 10.161'

Lamont

Argyle

Darlington

#18

Woodford

Wiota

Cuba City

To Monroe

Benton

Lead Mine

Shullsburg

Gratiot

South Wayne

Hazel Green

Strawbridge

New Diggings

**Legend**  
**Trails**

- Cheese Country Trail
- Pecatonica Trail



1 inch = 19,250 feet

# Cheese Country & Pecatonica Trails



Lafayette County Land Information  
www.lafayettecountywi.org/lgi

Map features are a representation only and do not replace a survey or other legally recorded documents.  
2015 Aerial Imagery

Map Created: April 2019

