

State of Wisconsin
 Department of Natural Resources
dnr.wi.gov

Motorized Recreation Grant Application

For: (choose all that apply) Form 8700-159 (R 04/22)

Due Date: April 15 #5 Dane Badger Mill Creek Bridge

- ATV/UTV Trail Aid
 Snowmobile Trail Aid

Notice: Completion of this form is required under Wisconsin Statutes 23.09(26) and 23.33. Failure to complete this form will result in denial of financial assistance. Personally identifiable information found on this form is not intended to be used for any other purpose. The Department of Natural Resources (DNR) may provide this information to requesters as required by Wisconsin's Public Records law {ss. 19.31 – 19.39, Wis. Stats.}.

Instructions: Applications may combine more than one source of funds. They may be submitted for consideration of traditional ATV, UTV, Snowmobile and Motorized Stewardship funding. Submit one copy of all forms and attachments. See Page 2 for necessary attachments. Send applications to your [Community Services Specialist](#).

DNR Use Only	
Category	Number

Section 1: Applicant Information

Applicant / Organization Name Dane County Parks			Check Recipient: Individual other than authorized individual to act on behalf of the applicant. <input type="checkbox"/> Select if the same as applicant.		
Individual Authorized to Act on Behalf of Applicant per Resolution Joleen Stinson			Check Recipient Name (Name to Appear on Check) County of Dane		
Title Interim Parks Director			Title		
Address 5201 Fen Oak Dr, Room 208			Address 5201 Fen Oak Dr, Room 208		
City Madison	State WI	ZIP Code 53718	City Madison	State WI	ZIP Code 53718
Telephone Number (608) 422-0657		Email Address stinson.joleen@countyofdane.com			

Section 2: Project Information Required for all Projects

Project Title Dane County Trail Maintenance					Current Funded Miles 407.8	New Miles (if applicable) 1.46
County Dane	Township N	Range <input type="radio"/> E <input type="radio"/> W	Section 1/4 1/4	1/4	GPS Coordinates: Lat. _____ Long. _____	

Project Description Summary
 Dane County requests funding to maintain 407.8 miles of approved snowmobile trails within the county. Dane County further request the addition of 1.46 funded miles to cover a critical trail segment connecting Columbia with Dane County. Finally Dane County requests funding to install a new bridge crossing over the Badger Mill Creek (replacing culverts) on trail #38, which is on a recently acquired Dane County Parks property.

I certify that all maintenance land use agreements are on file.

Estimated Cost

Maintenance	Acquisition	Insurance	Development	Bridge Rehab.	Trail Rehab.	Total Estimated Cost
\$122,340.00				\$100,000.00		\$222,340.00
Leave Blank – DNR Use Only						

Applicant Certification

Printed Name of Authorized Official Joleen Stinson	Official's Title Parks Director
--	---

As the applicant's authorized official, I certify that, to the best of my knowledge, the information in this application is true and correct.

 Signature of Authorized Official

4/13/2023
 Date Prepared

Dane County Snowmobile Trails Winter 2023-2025

0 0.5 1 1.5 2 2.5 Miles

- Corridor Number
- Trail Number
- Club Trail
- County Trail
- State Corridor Trail
- Region Lines
- Gas Available
- Park & Ride Lot
- Intersection
- Advertiser

DANE COUNTY SHERIFF'S OFFICE
 Emergency 911
 Non-Emergency Communications Center
 255-2345

Region Boundaries

NW: Hwy. 12
 Military Ridge Trail

NC: Hwy. 12 Hwy. 151
 I-90/99 Hwy. N

NE: Hwy. N I-90
 Hwy. 151 I-94

SW: Military Ridge Trail
 Hwy. 14

SE: I-94
 Hwy. 14

Note: Military Ridge Trail is open if either the NW or SW regions are open.

RIDING INTO ANOTHER COUNTY?

Trail hot-line numbers are listed on the margins of this map for all adjacent counties.

WisDOT Park & Ride Lots in Dane County

Dane County has several Wis DOT Park & Ride lots, and four are located with easy trail access. Wis DOT officials have informed us that usage of these lots by snowmobilers would be acceptable as long as the posted restrictions are followed. Specific restrictions for the lots can also be found at www.dot.wisconsin.gov/travel/parki/index.htm. Snowmobilers should park their vehicles with due regard for available space and if a chosen lot is near full, please consider another location for parking. Park & Ride lots with nearby trail access are designated with this map symbol.

Other Park and Ride Locations

Many business places and other private/public locations are available for visiting snowmobilers to park, unload, and ride in Dane County. Please check some of the map ads or inquire locally for their locations.

Dane County Council of Snowmobile Clubs thanks the Dane County Land and Water Resources Department for their assistance and data that was used to prepare the base map, as well as their GIS assistance to accurately show the trail system and our commercial sponsors.

NOTICE TO ALL SNOWMOBILERS

It is YOUR responsibility to know if trails are open or closed.

Because of the large number of miles of trails in Dane County, numerous region and county-line crossings, and many trail intersections, it is not possible for ALL trail access points to be signed as OPEN or CLOSED.

BE SURE YOU CALL THE TRAIL HOT-LINE NUMBER (608) 242-4576 BEFORE YOU RIDE!

Trail openings/closings and maps are also available at www.daneconomy.com/snowmobileclubs and www.countyofdane.com/wrd/parks/

Notice - ALL snowmobiles must display a current trail pass.

- NORTHWEST REGION**
- Premier Co-op Mt Horob
 - Riley Tavern
 - It's Time Grill & Pub
 - Morgan's Bar & Grill
 - The Shack Bar
 - Premier Co-op Black Earth
 - The Shoe Box
 - BP Gas Station
 - Rookie's Food & Spirits
 - Handelbar Performance
 - Mazo Hardware & Rental
 - R & J's Saloon
 - Connie's Home Plate
 - Mobil Kelley's Market

- NORTH CENTRAL REGION**
- Green Acres
 - Dorf Haus
 - On The Rox
 - Springfield Corners
 - Missouri Tavern
 - Dane Kwik Mart
 - Tootie's Bar & Grill
 - The Ranch Saloon

- Peg & Doc's Bar & Grill
- Rea's Innkeeper
- Mr. Brews Taphouse
- Buck & Honey's
- Meffert Oil Company
- Culver's - Waunakee
- Carl F. Statz & Sons
- The Willows Tavern
- Pink Elephant Shell
- Culver's - DeForest
- Rodeside Grill
- Mad City Powersports
- Club 51
- The Timbers
- The Frog Pond

- COLUMBIA COUNTY ADVERTISERS**
- KD's Bar & Grill
 - Johnson Sales
 - Sassy Cow
 - Club 60
- NORTHEAST REGION**
- Easy Landing
 - The Barrel Inn
 - Marshall Sno Drifters
 - The Badger Bar
 - The Fox Bar & Grille
 - Chicken Licks

- SOUTHWEST REGION**
- Doubleday's
 - Powersports Solutions
 - Olde Town Coffee House
 - Outpost Bar & Grill
 - 1855 Saloon & Grill
 - Safeguard Storage
 - The House of Syn
 - Nora's Tavern
 - Utica Nora Rockdale Trailblazers
 - Deerfield Rod & Gun
 - The Rail House

- Prairie Riders
- Seminary Springs Tavern
- Shack's Tap
- Kurt's Never Inn
- Flannel Frontier Bar & Grill
- The Pickle Tree
- London Depot
- Kroghville Oasis
- Rockdale Bar & Grill
- Utica Bar
- East Side Automotive
- Springer's of Lake Kegonsa
- Quam's Marine & Motorsports
- Quick Stop BP
- Tom's Auto Center

- JEFFERSON COUNTY ADVERTISERS**
- John Hartwig Motorsports, Inc
 - The Sports Page Bar & Grill
- SOUTHWEST REGION**
- Engelhart
 - Mulligan's
 - Headquarter's
 - Dave's White Rock Bar
 - Anchor Club II
 - Paoli Pub
 - Dot's Tavern
 - Schwoegler's Sugar River Lanes
 - The Dam Bar & Grill
 - Al's Dayton Place

- GREEN COUNTY ADVERTISERS**
- Main Street Music & More
- LAFAYETTE COUNTY ADVERTISERS**
- Rachel & Ray's Pub and Grill
- GRANT COUNTY ADVERTISERS**
- Funk's Tree Services & Landscaping
- AMMENITIES**
- Gas
 - Trailer Parking
 - Gas & Trailer Parking

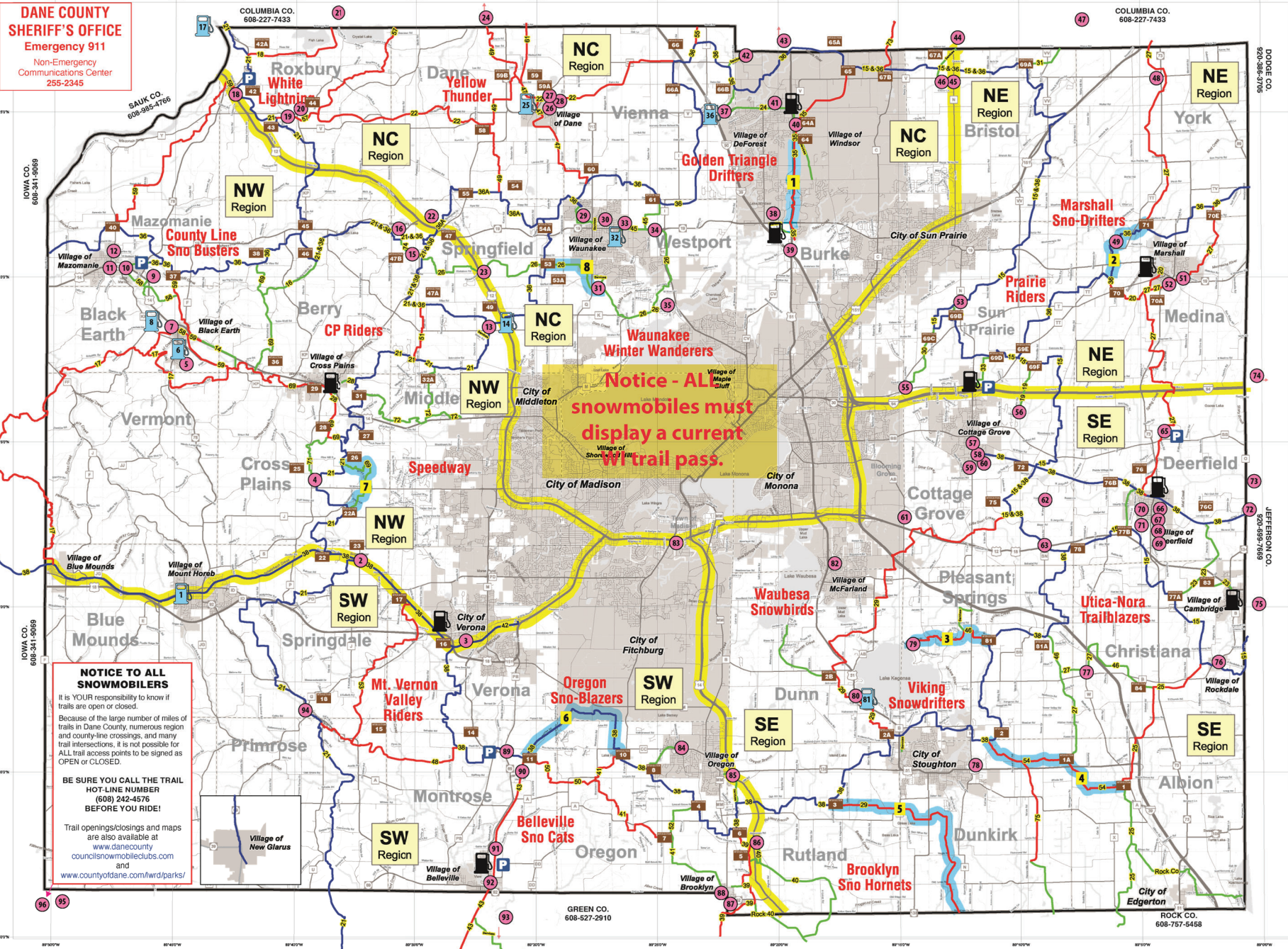



Dane County Land & Water Resources Department
Parks Division

Joleen Stinson, Parks Director
Laura M. Hicklin, Director
Joe Parisi, Dane County Executive

**Dane County 2023 – 2024 Snowmobile Trail Aids Grant Request
Priority Project List Ranking for Dane County**

1. **New Bridge over Badger Mill Creek on Dane County Park property**

Dane County purchased this property in the fall of 2020. Dane County Land & Water Resources Department is planning a streambank restoration project and conversion of croplands to prairie to reduce the amount of runoff into the Badger Mill Creek and the Sugar River, providing groundwater protection and improved water quality. As part of the streambank restoration project, the culverts will be removed. New snowmobile bridge is needed to maintain this critical snowmobile trail crossing over of the Badger Mill Creek.

2. **New Trail Miles Providing a Connection to Columbia County**

Trail 31 connects state corridor 11 in Columbia County with state corridors 15 and 36 in Dane County. This trail provides direct access between Dane and Columbia Counties.

Existing Culverts Crossing Badger Mill Creek, Dane County Inventory #40



Dane County Snowmobile Trails Winter 2023-2025

- Corridor Number
- Trail Number
- Club Trail
- County Trail
- State Corridor Trail
- Region Lines
- Gas Available
- Park & Ride Lot
- Intersection
- Advertiser

- Region Boundaries**
- NW: Hwy. 12 Military Ridge Trail
 - NC: Hwy. 12 Hwy 151 Hwy 909 Hwy N
 - NE: Hwy N Hwy 151 I-94
 - SW: Military Ridge Trail Hwy. 14
 - SE: I-94 Hwy. 14
- Note: Military Ridge Trail is open if either the NW or SW regions are open.

RIDING INTO ANOTHER COUNTY?

Trail hot-line numbers are listed on the margins of this map for all adjacent counties.

WisDOT Park & Ride Lots in Dane County

Dane County has several Wis DOT Park & Ride lots, and four are located with easy trail access. Wis DOT officials have informed us that usage of these lots by snowmobilers would be acceptable as long as the posted restrictions are followed. Specific restrictions for the lots can also be found at www.dot.wisconsin.gov/travel/parki/defindex.htm. Snowmobilers should park their vehicles with due regard for available space and if a chosen lot is near full, please consider another location for parking. Park & Ride lots with nearby trail access are designated with this map symbol.

Other Park and Ride Locations

Many business places and other public locations are available for visiting snowmobilers to park, unload, and ride in Dane County. Please check some of the map ads or inquire locally for their locations.

Dane County Council of Snowmobile Clubs thanks the Dane County Land and Water Resources Department for their assistance and data that was used to prepare the base map, as well as their GIS assistance to accurately show the trail system and our commercial sponsors.

DANE COUNTY SHERIFF'S OFFICE
Emergency 911
Non-Emergency Communications Center 255-2345

NOTICE TO ALL SNOWMOBILERS

It is YOUR responsibility to know if trails are open or closed. Because of the large number of miles of trails in Dane County, numerous region and county-line crossings, and many trail intersections, it is not possible for ALL trail access points to be signed as OPEN or CLOSED.

BE SURE YOU CALL THE TRAIL HOT-LINE NUMBER (608) 242-4576 BEFORE YOU RIDE!

Trail openings/closings and maps are also available at www.dane-county.com/councilsnowmobileclubs.com and www.countyofdane.com/nrd/parks/

Notice - ALL snowmobiles must display a current trail pass.

Proposed new bridge location
Dane 40

- NORTHWEST REGION**
1. Premier Co-op Mt Horob
 2. Riley Tavern
 3. It's Time Grill & Pub
 4. Morgan's Bar & Grill
 5. The Shack Bar
 6. Premier Co-op Black Earth
 7. The Shoe Box
 8. BP Gas Station
 9. Rooke's Food & Spirits
 10. Handalbar Performance
 11. Mazo Hardware & Rental
 12. R & J's Saloon
 13. Connie's Home Plate
 14. Mobil Kelley's Market

- 15. R Bar**
16. The Whippoorwill / The Hawk's Nest
- SAUK COUNTY ADVERTISERS**
17. Prairie Cenex
 21. Schoepp's Bar
- NORTH CENTRAL REGION**
18. Green Acres
 19. Dorf Haus
 20. On The Rox
 22. Springfield Corners
 23. Missouri Tavern
 25. Dane Kwik Mart
 26. Tootie's Bar & Grill
 27. The Ranch Saloon

28. Peg & Doc's Bar & Grill
29. Rex's Innkeeper
30. Mr. Brews Taphouse
31. Buck & Honey's
32. Meffert Oil Company
33. Culver's - Waunakee
34. Carl F. Statz & Sons
35. The Willows Tavern
36. Pink Elephant Shell
37. Culver's - DeForest
38. Rodeside Grill
39. Mad City Powersports
40. Club 51
41. The Timbers
42. The Frog Pond

- COLUMBIA COUNTY ADVERTISERS**
24. KD's Bar & Grill
 23. Culver's - Waunakee
 47. Sassy Cow
 44. Club 60
- NORTHEAST REGION**
48. Easy Landing
 49. The Barrel Inn
 50. Marshall Sno Drifters
 51. The Badger Bar
 52. The Fox Bar & Grille
 53. Chicken Licks

54. Prairie Riders
 55. Seminary Springs Tavern
- SOUTHEAST REGION**
56. Doubleday's
 57. Powersports Solutions
 58. Olde Town Coffee House
 59. Outpost Bar & Grill
 60. 1855 Saloon & Grill
 61. Safeguard Storage
 62. The House of Syn
 63. Nora's Tavern
 64. Utica Nora Rockdale Trailblazers
 65. Deerfield Rod & Gun
 66. The Rail House

67. Badger Realty
68. Shack's Tap
69. Kurt's Never Inn
70. Flannel Frontier Bar & Grill
71. The Pickle Tree
72. London Depot
73. Kroghville Oasis
76. Rockdale Bar & Grill
77. Utica Bar
78. East Side Automotive
79. Springer's of Lake Kegonsa
80. Quam's Marine & Motorsports
81. Quick Stop BP
82. Tom's Auto Center

- JEFFERSON COUNTY ADVERTISERS**
74. John Hartwig Motorsports, Inc
 75. The Sports Page Bar & Grill
- SOUTHWEST REGION**
83. Engelhart
 84. Mulligan's
 85. Headquarter's
 86. Dave's White Rock Bar
 87. Anchor Club II
 89. Paoli Pub
 90. Dot's Tavern
 91. Schwoegler's Sugar River Lanes
 92. The Dam Bar & Grill
 93. Al's Dayton Place

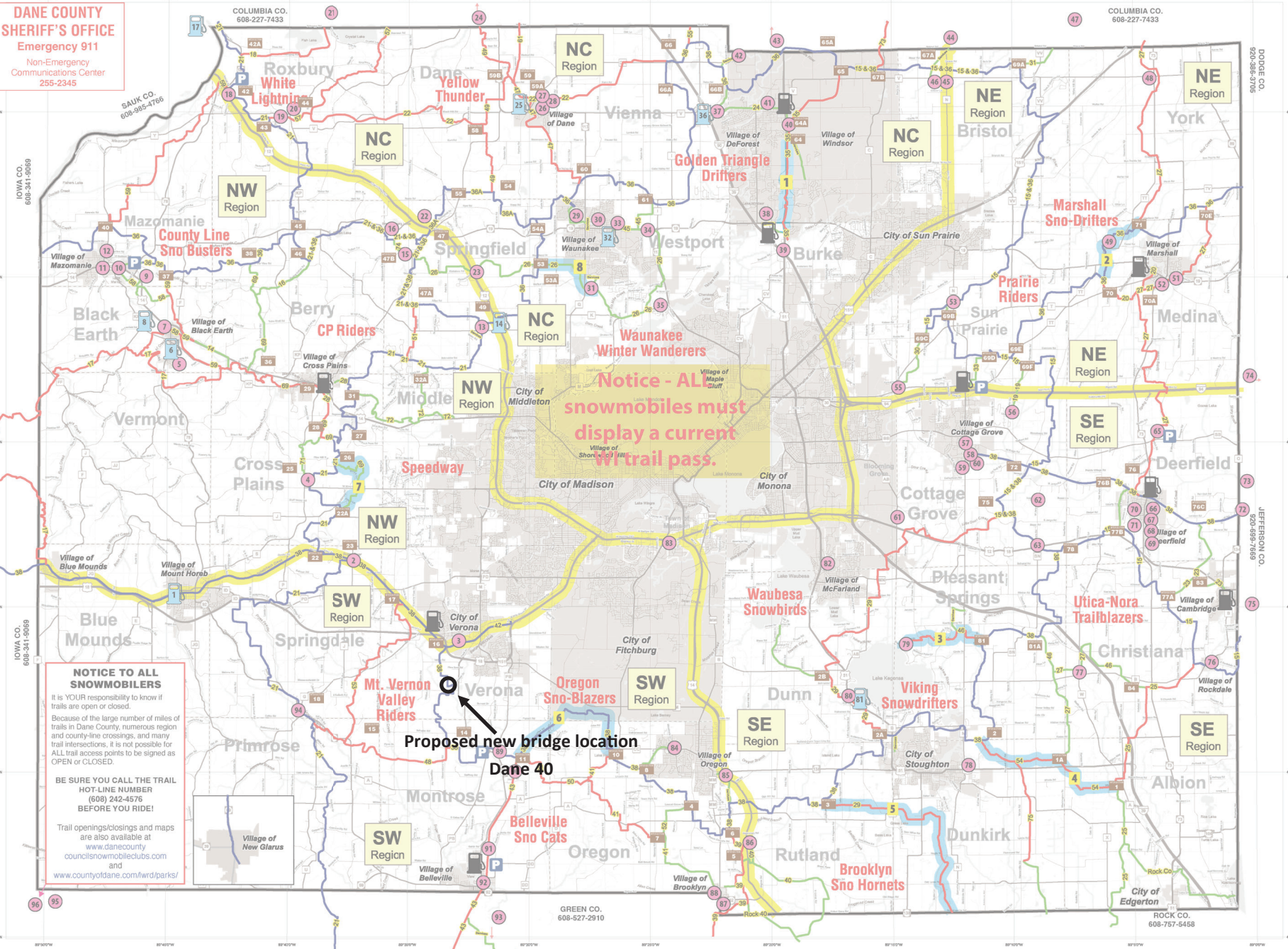

94. Mt. Vernon Tap
- GREEN COUNTY ADVERTISERS**
88. Main Street Music & More
- LAFAYETTE COUNTY ADVERTISERS**
95. Rachel & Ray's Pub and Grill
- GRANT COUNTY ADVERTISERS**
96. Funk's Tree Services & Landscaping
- AMMENITIES**
- Gas
 - Trailer Parking
 - Gas & Trailer Parking



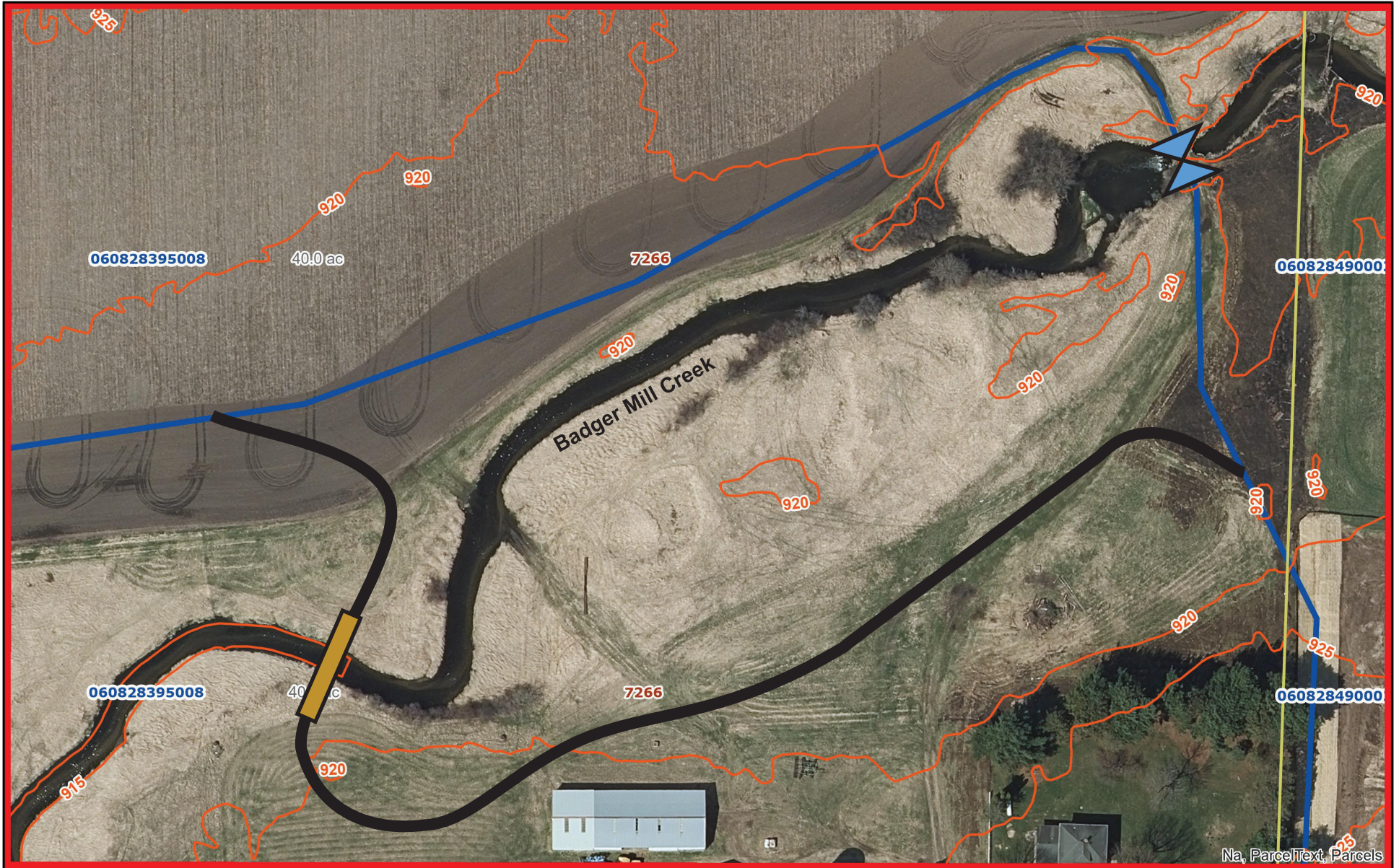

Dane County Snowmobile Trail New Bridge Application Map



April 12, 2023

-  Proposed Bridge
-  Current Culverts

-  Proposed Reroute
-  State Trail 38
-  Parcels

- 5 foot Intervals**
-  Index
 -  Index Depression

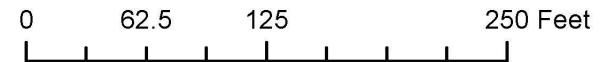

Na, ParcelText, Parcels

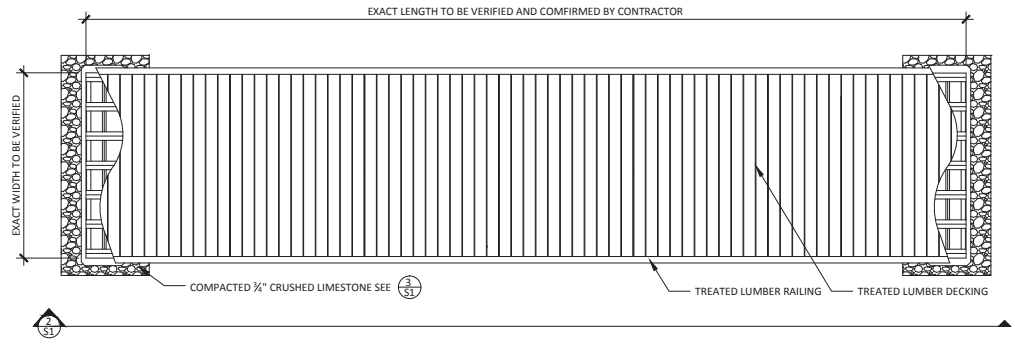

1 BRIDGE PLAN
S1
1/4" = 1'-0"

NOTES:

GENERAL NOTES:

1. DANE COUNTY IS NOT RESPONSIBLE FOR CONSTRUCTION MEANS OR METHODS OR FOR SUPERVISION OF CONSTRUCTION
2. ALL DIMENSIONS SHALL BE FIELD VERIFIED BY CONTRACTOR PRIOR TO BRIDGE FABRICATION. ANY DIMENSIONAL DISCREPANCIES ARE TO BE BROUGHT TO THE ATTENTION OF THE DANE COUNTY PUBLIC WORKS ENGINEERING DIVISION PRIOR TO PROCEEDING WITH FABRICATION OF THE BRIDGE. FINAL PLANS AND SPECIFICATIONS SHALL BE STAMPED ENGINEERING DRAWINGS APPROVED BY A WISCONSIN REGISTERED STRUCTURAL ENGINEER OR PREVIOUSLY APPROVED DRAWINGS.
3. ALL WORK IS TO BE PERFORMED IN A SAFE AND WORKMAN-LIKE MANNER IN COMPLIANCE WITH THE FEDERAL OCCUPATIONAL SAFETY AND HEALTH ACT (OSHA) AND ALL STATE OF WISCONSIN BUILDING CODES AND ZONING ORDINANCES AS THEY MAY PERTAIN TO THIS PROJECT. THE CONTRACTOR MUST COMPLY WITH ALL WISCONSIN DEPARTMENT OF NATURAL RESOURCES (WDNR) AND ARMY CORPS OF ENGINEERS RULES AND REGULATIONS ASSOCIATED WITH CROSSING WATERWAYS. DANE COUNTY PARKS DIVISION WILL SECURE ALL NECESSARY WATER REGULATORY PERMITS AND APPROVALS FROM THE WISCONSIN DNR AND ARMY CORPS OF ENGINEERS AND DANE COUNTY PRIOR TO CONSTRUCTION. CONTRACTOR MUST ADHERE TO THE WDNR CHAPTER 30 PERMIT AND THE DANE COUNTY SHORELAND EROSION CONTROL PERMIT REQUIREMENTS WHILE COMPLETING THE CONSTRUCTION OF THE BRIDGE.
4. THE CONTRACTOR IS RESPONSIBLE FOR ALL TEMPORARY BRACING DURING HANDLING AND ERECTION OF THE BRIDGE.

SITE WORK:

1. CONTRACTOR IS TO PROVIDE FINAL BRIDGE DESIGN WITH NECESSARY APPROACHES AND STRUCTURAL ELEMENTS FOR APPROVAL BY DANE COUNTY PARKS.
2. THE CONTRACTOR IS TO VERIFY ALL CONDITIONS AT THE SITE, PARTICULARLY THE LOCATION OF ANY UNDERGROUND UTILITIES BEFORE EXCAVATION. ANY DISCREPANCIES ARE TO BE BROUGHT TO THE ATTENTION OF DANE COUNTY PUBLIC WORKS ENGINEERING DIVISION.
3. THE CONTRACTOR IS RESPONSIBLE FOR SOIL COMPACTION TESTING AND FOR PROVIDING A BRIDGE DESIGN TO MEET THE SOIL TYPE.
4. THE BEARING ELEVATION OF THE BRIDGE SHALL BE SET AT AN ELEVATION SUCH THAT THE MINIMUM BOTTOM CHORD ELEVATION OF THE BRIDGE SHALL BE 5'-0" ABOVE THE ORDINARY HIGH WATER MARK. THE ORDINARY HIGH WATER MARK IS THE POINT ON THE BANK OR SHORE UP TO WHICH THE PRESENCE AND ACTION OF THE WATER IS SO CONTINUOUS AS TO LEAVE A DISTINCT MARK EITHER BY EROSION, DESTRUCTION OR TERRESTRIAL (LAND) VEGETATION, OR OTHER EASILY RECOGNIZED CHARACTERISTIC.

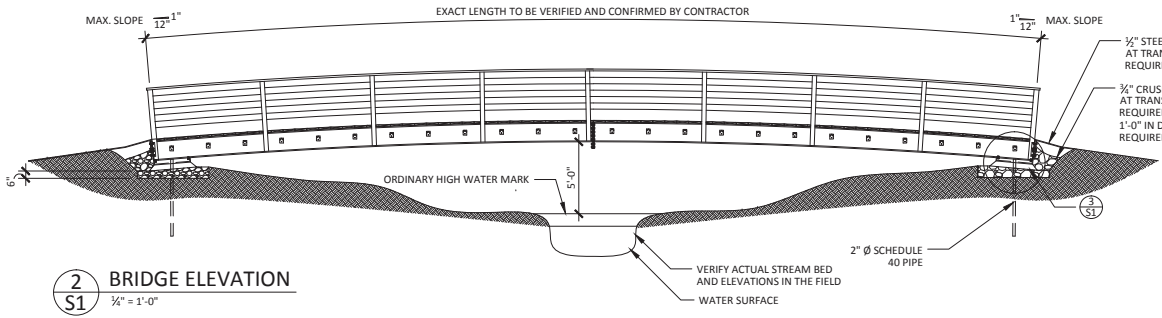

2 BRIDGE ELEVATION
S1
1/4" = 1'-0"

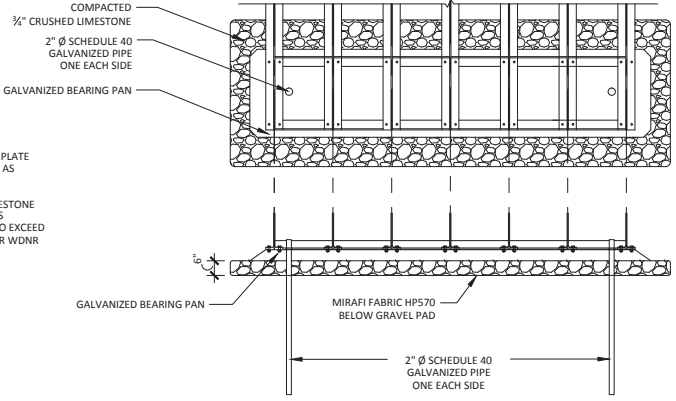

3 GRAVEL PAD & GALVANIZED BASE DETAILS
S1
1/2" = 1'-0"

BRIDGE APPROACH ALTERNATIVES:

AT GRADE BANK APPROACH OR ELEVATED BANK APPROACH

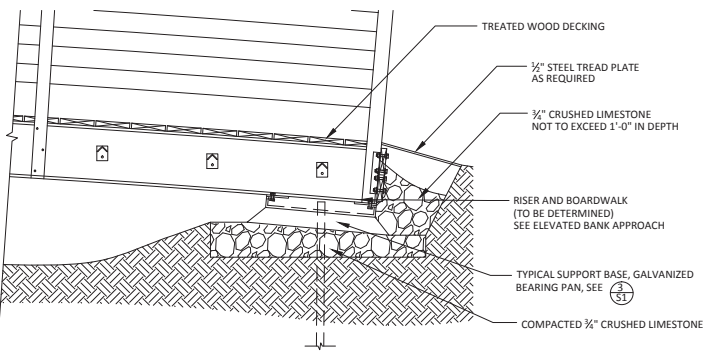

AT GRADE BANK APPROACH ALTERNATIVE
1/4" = 1'-0"

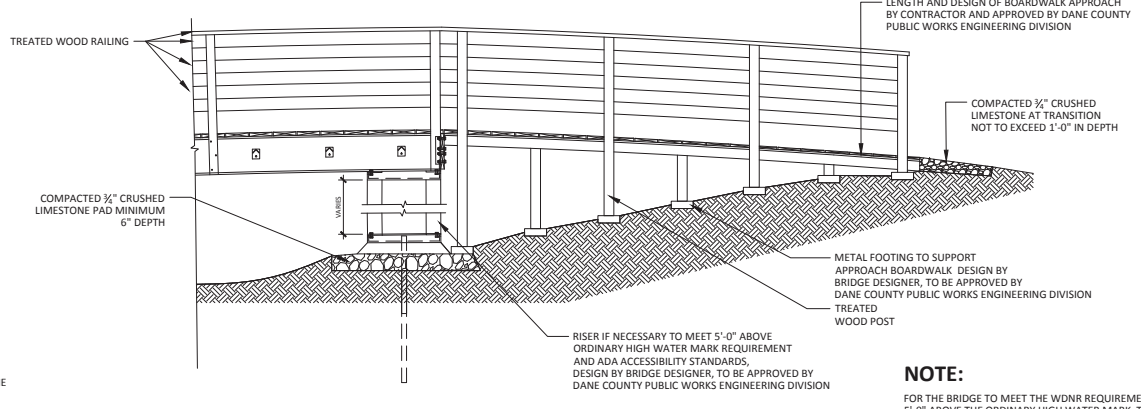

ELEVATED BANK APPROACH ALTERNATIVE
1/2" = 1'-0"

NOTE:

FOR THE BRIDGE TO MEET THE WDNR REQUIREMENT OF 5'-0" ABOVE THE ORDINARY HIGH WATER MARK, THE ADDITION OF STEEL RISERS MAY BE NEEDED WITH A BOARDWALK APPROACH TO THE BRIDGE. SEE: ELEVATED BANK APPROACH ALTERNATIVE
BRIDGE, BOARDWALK APPROACH (IF NECESSARY) AND GRAVEL APPROACHES MUST MEET THE REQUIREMENTS OF THE AMERICANS WITH DISABILITIES ACT (ADA)

Appendix A – Required for Bridge Rehab/Replace, New, or Reroute with New Bridge

Bridge Rehab/Replace New Bridge Reroute with new bridge

County Dane	Township 06 N	Range 8	<input checked="" type="radio"/> E <input type="radio"/> W	Section 28	¼ ¼ SE	¼ SW	GPS Coordinates: Lat. 42.959782 Long. -89.557323
Water Body Name Badger Mill Creek				Bridge Name Badger Mill Creek - DCP Culvert			County Inventory Number Dane 40
Funded Trail Name or Number (SNARS if applicable) 38				Has this bridge site ever received development or rehabilitation funds in the past? <input type="radio"/> Yes <input checked="" type="radio"/> No Year: _____ \$ _____			
Bridge is located on: <input type="radio"/> Private property <input checked="" type="radio"/> Public property				Old Bridge/Culvert Size 1 culvert ~ 60" x 25' New Bridge/Culvert Size 70' x 12'			
Landowner Where Bridge is Located Dane County				Telephone Number (608) 422-0657		Length of Trail Use Agreement (5 year minimum) permanent public ownership	
Current maximum load _____ lbs.		Age of Bridge		Bridge Material			
Proposed maximum load 25,000 lbs.		n/a		culverts			
Sponsoring Club Name				Club Contact		Telephone Number	
Do you have your trail bridges posted as to maximum load? <input type="radio"/> Yes <input checked="" type="radio"/> No				What is the maximum load of the other bridges on the system if groomed with this bridge?			
What is the weight of your puller & drag/grading equipment? 12,000 lbs							
What other recreational trail uses are planned for this bridge? none							
If there are other Recreational uses planned, how much of the bridge cost will be paid for by non-snowmobile or non-ATV users?							

- Yes No Have you contacted your local [DNR Water Management Specialist \(WMS\)](#) regarding a permit?
- Yes No Is a permit needed? (Please provide any written correspondence from WMS.)
- Yes No Have you contacted your County Zoning Dept. regarding a floodplain determination?
- Yes No Will an H & H (hydrologic and hydraulic) study be required?

Bridge Project Detailed Description

Dane County purchased this property, which is approximately 160 acres, in the fall of 2020. This property contains over 1,900 feet of two bank frontage along Badger Mill Creek and 1,775 feet on the Sugar River and the confluence of the two streams sits in the southern portion of the property. Both are classified as Tier I Streams in the Dane County Parks & Open Space Plan. Acquisition of this property protected these water resources. Dane County Land & Water Resources Department is planning a streambank restoration project and conversion of croplands to prairie to reduce the amount of runoff into the streams providing groundwater protection and improved water quality. Restoration will also enhance wetland functions, enabling more floodwater storage while also providing improved fish and wildlife habitat. As part of the streambank restoration project, the culverts will be removed.

A new snowmobile bridge is needed to maintain this critical snowmobile trail crossing over of the Badger Mill Creek. The new bridge creek crossing is proposed to be shifted slightly to the west on the same property. This location was selected because the creek is relatively stable and low energy, and because this is where the band of riparian wetlands is the narrowest.

This property is classified as a Natural Resource Area (NRA). Dane County NRAs are lands designated for the protection of a valuable natural environment, wildlife habitat, open space, and/or greenbelt corridor. Recreation at NRAs is a secondary objective, with limited to no developed facilities. Therefore, there are no formal trails planned for this property and the new bridge would be used primarily for snowmobiles.

Appendix A (continued)

Summarize Costs in Appropriate Categories:

Bridge Structure

	Quote 1	Quote 2
	<input checked="" type="radio"/> Steel <input type="radio"/> Wooden	<input checked="" type="radio"/> Steel <input type="radio"/> Wooden
Bridge Dimensions:	70' x 12'	80' x 12'
Bridge Manufacturer:	Anderson Bridges	Custom Manufacturing, Inc
Design Weight Load	25,000 lbs.	25,000 lbs.
Cost of Structure:		
1. Engineering	\$ 4,000	\$ 3,000
2. Structure	\$ 74,000	\$ 87,900
Subtotal	\$ 78,000	\$ 90,900

	Quote 1	Quote 2
	<input checked="" type="radio"/> Contractor or <input type="radio"/> Sponsor Estimate	<input checked="" type="radio"/> Contractor or <input type="radio"/> Sponsor Estimate
Installation Costs:		
1. Engineering	\$ _____	\$ _____
2. Site Preparation	\$ 5,000	\$ 8,500
3. Abutments	\$ 10,000	\$ _____
4. Pilings/Piers	\$ _____	\$ _____
5. Approaches	\$ _____	\$ _____
6. Riprap	\$ 2,000	\$ _____
7. Labor	\$ 5,000	\$ _____
8. Equipment Rental	\$ _____	\$ 2,000
9. Culverts	\$ _____	\$ _____
10. H & H Study	\$ _____	\$ _____
11. Wetland Delineation	\$ _____	\$ _____
12. Other delivery	\$ _____	\$ 900
Subtotal	\$ 22,000	\$ 11,400
Total Cost	\$ 100,000	\$ 102,300

For the application grant, you must take the lowest of the two quotes.

Entire Deck and Railing Projects Contractor Sponsor Club

Bridge Dimensions:	_____
Design Weight Load	_____ lbs.
1. Materials	\$ _____
2. Labor	\$ _____
Total	\$ _____



111 Willow Street
Colfax, WI 54730
(715) 962-2800
FAX: (715) 962-2801

PROPOSAL

April 11, 2023

To: Dane County Snowmobile Trail Administrator

Re: Badger Mill Creek Snowmobile Bridge Budget

- 1 - **70' x 12' (clear width)** arched steel truss bridge
 - Design Standards: **AASHTO**
 - Diagonals per Panel: **1**
 - Clear width: **Inside face structural elements at deck level**
 - End Vertical: **Square**
 - Bearings: **Equal Elevations**
 - Steel Grade: **A588/A847 (Unpainted self-weathering)**
 - Deck: **#1 Southern Yellow Pine (.40 MCA)**
 - Safety Rails: **Horizontal (4" opening)**
 - Installation: **Steel piling abutments**
 - Loads: **85 psf live load - 35 psf wind load – 25,000 lbs. vehicle load**
 - FOB: **Dane County, WI**
 - Engineered Drawings State Seal: **Wisconsin**

Price-----\$100,000

• Structure (Steel Truss)	\$74,000
• Engineering	\$4,000
• Soil Testing	\$0
• Site Prep	\$5,000
• Abutments	\$10,000
• Labor	\$5,000
• Rip Rap	\$2,000

*****This price is for budgetary purposes only*****

Please call with any questions.

Thank you,

Kory S. Weathers



Custom Manufacturing, Inc.

606 Delco Drive, P.O. Box 279

Clinton, WI 53525

608-676-2282 Fax: 608-676-2283

tina@custommfginc.com

Quotation 6250

Please Indicate The Above Number When Ordering

To: Dane County Parks Department
4318 Robertson Rd
Madison, WI 53718

Date: April 8, 2023	Salesperson: Tina Forrest
Inquiry Date:	Inquiry Number

Estimated Ship Date 8 - 12 weeks	Shipped VIA Best way	F.O.B Clinton, WI	Terms Net 30		
			Description	Price	Total
			2023 GRANT APPLICATION ESTIMATE Rhiner Bridge		
1			40' Arched Bridge w/ 2 - 20' Approaches (80' total) - 12' Wide - 25,000# Load Double Decked - 42" Horizontal Railing - Hardware On 2 sets of Galvanized Riser Pans	\$ 87,900.00	
			Stamped Engineered Drawings	3,000.00	
			Installation & Site Preparation	8,500.00	
			Equipment Rental	2,000.00	
			Delivery Charges	900.00	
			Total		\$ 102,300.00
			Above prices do not include sales tax or any necessary permits.		
			Bridge kit includes all Steel I-Beams and Crossmembers, which are predrilled and have a red oxide primer finish, MCA Southern Yellow Pine treated lumber and all hardware. All lumber is Pre Stained.		
			Bridge Kit Meets - WI DNR Guidelines - 25,000# Load		

We are pleased to submit the above quotation for your consideration. Should you place an order, be assured it will receive our prompt attention. This quotation is valid for 30 days. Thereafter it is subject to change without notice.

BY: Tina Forrest

ACCEPTED: _____

DATE: _____